

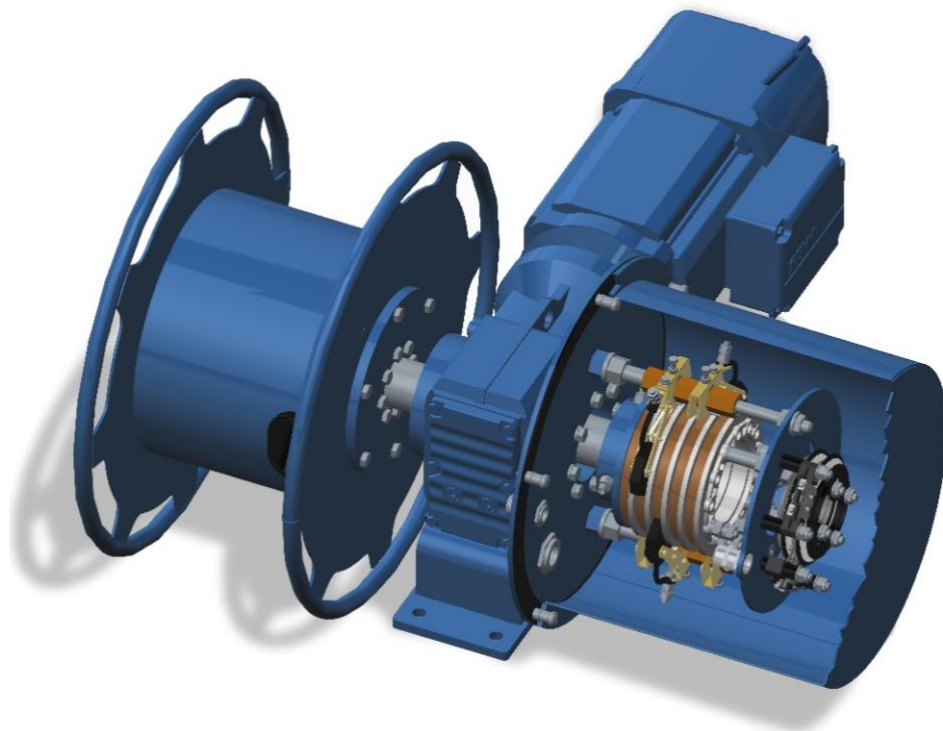

# Elektrotechnische Geräte Böhlitz-Ehrenberg GmbH

---

**Your specialist for spring and motor cable  
reels and slip ring assemblies  
for use in sewage treatment plants**



**We offer:**

- **Project planning, new construction, and conversion according to your specifications or joint technical design on request**
- **Regular maintenance service**
- **Modernisation of your systems and repairs**
- **Immediate assistance in the event of a fault, even with units from other manufacturers**
- **Spare parts service**



# Elektrotechnische Geräte Böhlitz-Ehrenberg GmbH

## Proven sewage treatment plant technology from EGB

Our spring and motorised cable reels are technologically mature and proven transmission systems for energy, control signals and data for mobile consumers. They are therefore the first choice and the perfect technical solution for a reliable power supply in a wide range of industrial applications.



### Motorised cable reels for longitudinal and circular scrapers in sewage treatment plants

**Long service life** thanks to wear-free, reliable and highly efficient components and therefore **low maintenance cycles**.

**Robust design** for 24/7 operation in all weathers.

**Optimum corrosion protection** even under the most aggressive environmental conditions. Drum body and side wall made of hot-dip galvanised steel or stainless steel. Multiple or special paint finishes are also possible.

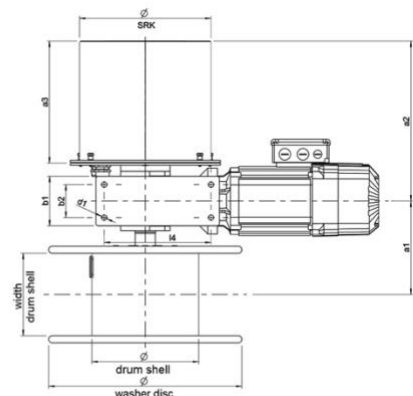
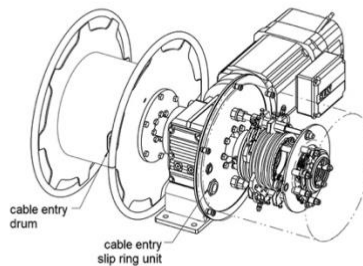
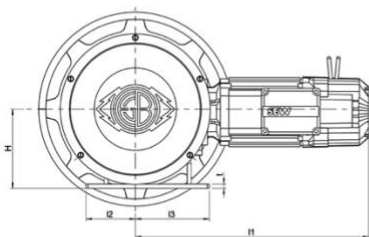

### Product features of our motorised cable reels

- Wide, spiral or wild-wound reel bodies
- Realisable cable pull-off length of up to 100 m
- Slip ring bodies for the safe and reliable transmission of power, control, data, bus and video signals, integration of fibre optic cables possible
- Can be realised in combination with a rotary feed-through for hoses for the transmission of liquid or gaseous media
- Protection class: IP 55 (standard) to IP 65, higher protection classes on request
- Combinable with all common motor drives
- High operational reliability even with vibrations and extreme temperatures or temperature fluctuations



# Elektrotechnische Geräte Böhlitz-Ehrenberg GmbH

## Accessories

- Strain relief reel and cable pulling grips: to absorb tensile forces on cable feeds and protect them
- Spooling devices: spindle- or chain-driven, these ensure that the cable is wound or unwound in an orderly manner on the reel body
- Cable deflection: deflection of the cable routing
- Cable support rollers: Support of the cable over a distance
- Geared cam limit switch: Monitoring of the operating states, reel "full" and "empty"
- Heating: recommended for extreme temperatures or temperature fluctuations
- Protective covers: protection against external influences



## Slip ring assembly for circular scrapers

We offer special types of slip ring assemblies for rotary scrapers in sewage treatment plants for power and data transmission from the stationary switching and monitoring system to the drives on the rotating rotary scraper bridge.

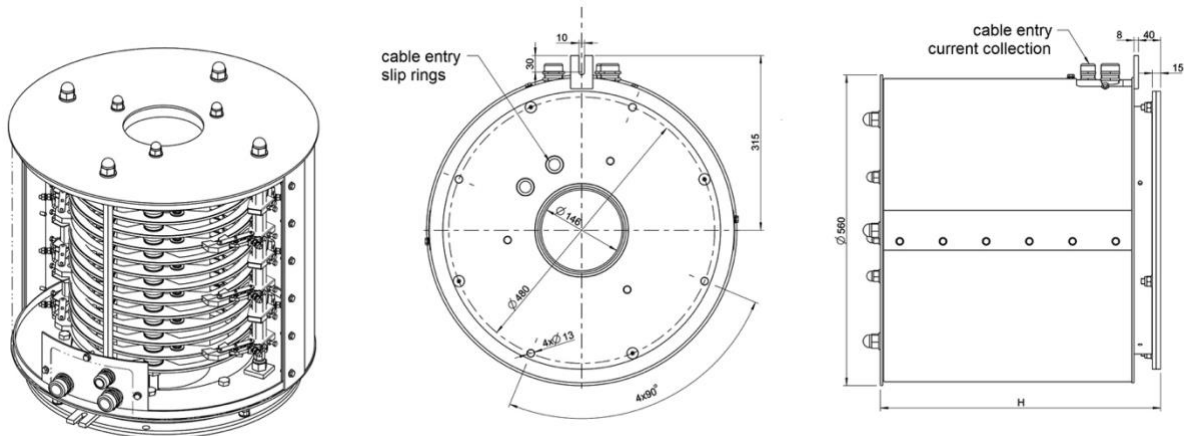

## Product features of our slip ring assemblies

- Encapsulated slip ring assemblies
- Internal thermally controlled heating
- Open inner diameter for pipe passages (sludge return)
- High-quality corrosion protection in hot-dip galvanised or stainless steel design
- Completely removable cover for optimum freedom of movement during maintenance work



# Elektrotechnische Geräte Böhlitz-Ehrenberg GmbH

## EGB, from the idea to the realisation - everything from a single source

Whether project planning and original equipment, modernisation, maintenance or repair, as a system supplier EGB offers its customers a comprehensive all-round service with expert advice.

With almost 100 years of experience in development, production, installation and commissioning, we are the right partner to realise your projects. Our spring and motorised cable reels for sewage treatment plant technology are just a small selection from our extensive portfolio of hose and cable reels, from small and handy to gigantic with up to 3,000 m realisable cable pull-off lengths.

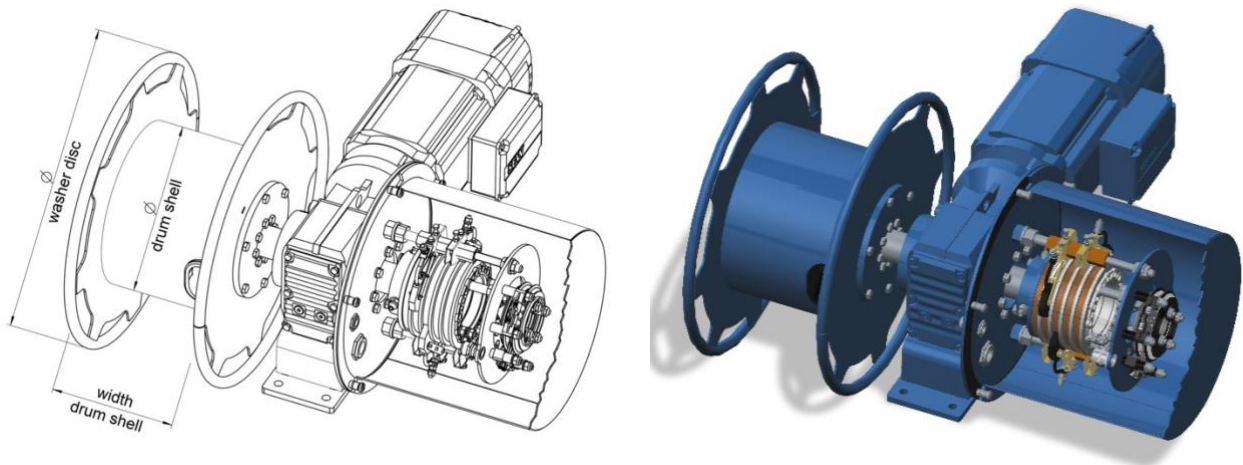

Visit us at: [www.egb-be.de](http://www.egb-be.de)

or meet us in person:

Ludwig-Hupfeld-Straße 6  
04178 Leipzig, Germany

 +49 341 44 81 0





# Elektrotechnische Geräte Böhlitz-Ehrenberg GmbH

## Information for enquiries about slip ring assemblies

### Technical data:

	<u>Ring group 1</u>	<u>Ring group</u>	<u>Ring group 3</u>	<u>Ring group 4</u>	<u>Ring group 5</u>
Rated current	..... A	..... A	..... A	..... A	..... A
Rated voltage	..... V	..... V	..... V	..... V	..... V
	<input type="checkbox"/> AC <input type="checkbox"/> DC	<input type="checkbox"/> AC <input type="checkbox"/> DC	<input type="checkbox"/> AC <input type="checkbox"/> DC	<input type="checkbox"/> AC <input type="checkbox"/> DC	<input type="checkbox"/> AC <input type="checkbox"/> DC
Duty cycle	..... % ED	..... % ED	..... % ED	..... % ED	..... % ED
Number of rings	..... + PE	..... + PE	..... + PE	..... + PE	..... + PE
Pre-wiring	..... m ..... mm <sup>2</sup>	..... m ..... mm <sup>2</sup>	..... m ..... mm <sup>2</sup>	..... m ..... mm <sup>2</sup>	..... m ..... mm <sup>2</sup>
	.....	.....	.....	.....	.....

### Usage: (please tick or add as appropriate)

<input type="checkbox"/> Main current	<input type="checkbox"/> Main current	<input type="checkbox"/> Main current	<input type="checkbox"/> Main current	<input type="checkbox"/> Main current
<input type="checkbox"/> Auxiliary current	<input type="checkbox"/> Auxiliary current	<input type="checkbox"/> Auxiliary current	<input type="checkbox"/> Auxiliary current	<input type="checkbox"/> Auxiliary current
<input type="checkbox"/> Control signals	<input type="checkbox"/> Control signals	<input type="checkbox"/> Control signals	<input type="checkbox"/> Control signals	<input type="checkbox"/> Control signals
<input type="checkbox"/> Phone/video signals	<input type="checkbox"/> Phone/video signals	<input type="checkbox"/> Phone/video signals	<input type="checkbox"/> Phone/video signals	<input type="checkbox"/> Phone/video signals
<input type="checkbox"/> Measuring signals	<input type="checkbox"/> Measuring signals	<input type="checkbox"/> Measuring signals	<input type="checkbox"/> Measuring signals	<input type="checkbox"/> Measuring signals
<input type="checkbox"/> data < 100 Mbit	<input type="checkbox"/> data < 100 Mbit	<input type="checkbox"/> data < 100 Mbit	<input type="checkbox"/> data < 100 Mbit	<input type="checkbox"/> data < 100 Mbit
<input type="checkbox"/> Fibre optic cable (FO)	<input type="checkbox"/> Fibre optic cable (FO)	<input type="checkbox"/> Fibre optic cable (FO)	<input type="checkbox"/> Fibre optic cable (FO)	<input type="checkbox"/> Fibre optic cable (FO)
<input type="checkbox"/> .....	<input type="checkbox"/> .....	<input type="checkbox"/> .....	<input type="checkbox"/> .....	<input type="checkbox"/> .....

### Thermostatically controlled heating

Protection level  IP 00  IP 43  IP 54  IP 55  IP 65  IP .....

Ambient temperature from .....°C up to .....°C, Environmental media.....

Speed of rotation ..... rotation/ min, Shock load.....

max. dimension (L x W x H) ..... mm x ..... mm x ..... mm

Free inner diameter (e.g. for a suction pipe or a column) ..... mm

Should the slip ring assembly be retrofitted around a column (separable rings)?  yes  no

### Cable feed-throughs to the slip rings

..... x M 12, ..... x M 16, ..... x M 20, ..... x M 25, ..... x M 32, ..... x M 40, ..... x M 50, ..... x M 63

### Cable feed-throughs to the current collectors

..... x M 12, ..... x M 16, ..... x M 20, ..... x M 25, ..... x M 32, ..... x M 40, ..... x M 50, ..... x M 63

### Further information / Accessories:

.....  
.....

If you have any queries or require further information, please contact our Head of Technology and Sales:

Mr. Frank-Michael Hirsch e-mail: frank-michael.hirsch@egb-be.de

phone: +49 341 44 81 – 122