

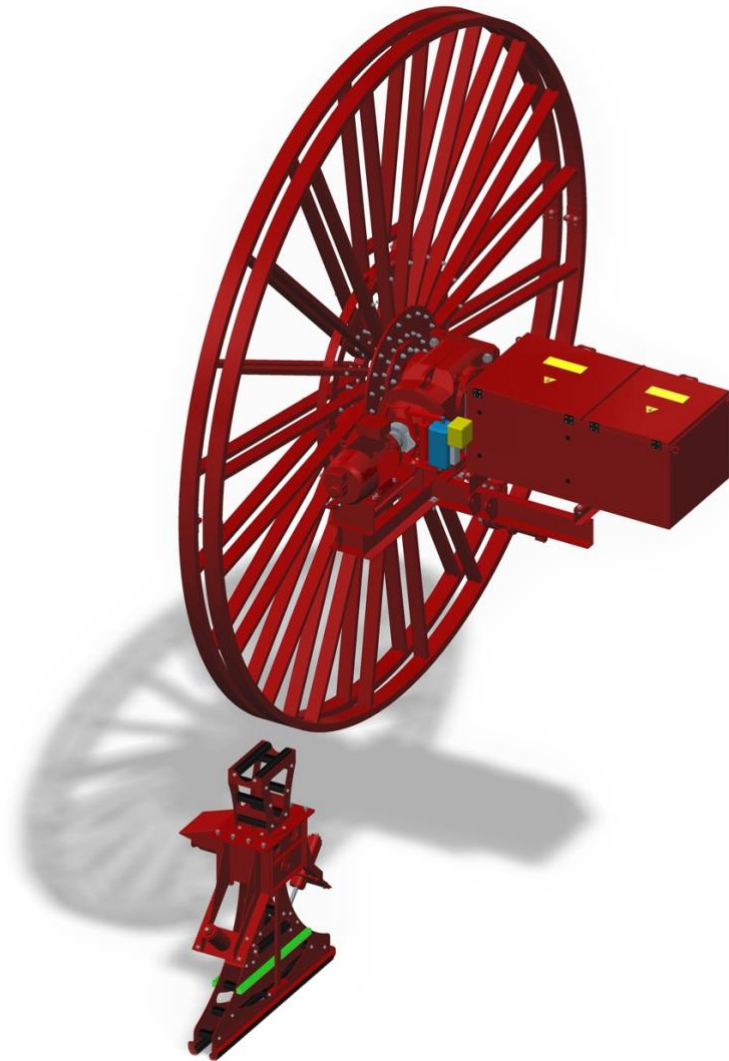

Elektrotechnische Geräte Böhlitz-Ehrenberg GmbH

Your specialist for spiral-wound cable reels



We offer:

- **Project planning, new construction and conversion according to your specifications or joint technical design on request**
- **Regular maintenance service**
- **Modernisation of your systems and repairs**
- **Immediate assistance in the event of a fault, even with units from other manufacturers**
- **Spare parts service**



Elektrotechnische Geräte Böhlitz-Ehrenberg GmbH

Spiral-wound cable reels from EGB

Spiral-wound cable reels with electric drive are used for the automatic winding of reeling cables up to a maximum length of 500 metres. It is possible to drive over the feed point with these cable reels. They are driven by a standstill motor or frequency-controlled.



Fields of application include:

- Crane systems of all kinds
- Container gantry cranes
- Crane runways
- Electric grabs
- Lifting magnets
- Conveyor systems

Energy transfer:

- Up to 690 V and 1,600 A in the low voltage range
- Up to 35,000 V and 600 A in the medium voltage range
- Suitable for the transmission of measuring and signalling current, optical signals, liquid or gaseous media, also possible in combination.

Controlled depositing and monitoring of the reel line is realised by an optional roller deflection.

Product features of our spiral-wound cable reels:

- Realisable cable run length of up to 500 m
- Slip ring assembly for the safe and reliable transmission of power, control, data, bus and video signals, integration of fibre optic cables possible
- Painted or stainless steel housing
- Can be realised in combination with a rotary feed-through for hoses for transmitting liquid or gaseous media
- Protection class: IP 55 (standard) to IP 65, higher protection classes on request
- Suitable for use at ambient temperatures from -40 °C to +60 °C
- For applications below -25 °C and for large temperature differences within short time intervals, we recommend installing a thermostatically controlled heater.
- Doppelspiralleitungstrommeln und Leitungstrommeln für die 3-2-3 Wicklung sind ebenfalls lieferbar.
- Double spiral cable reels and cable reels for 3-2-3 winding are also available
- Can be combined with all common motor drives
- High operational reliability even with vibrations and extreme temperatures or temperature fluctuations



Elektrotechnische Geräte Böhlitz-Ehrenberg GmbH

Accessories:

- Strain relief reel and cable pulling grips: to absorb tensile forces on cable feeds and protect them
- Spooling devices: spindle- or chain-driven, these ensure that the cable is wound or unwound in an orderly manner on the reel body
- Cable deflection: deflection of the cable routing
- Cable support rollers: Support of the cable over a distance
- Geared cam limit switch: Monitoring of the operating states, reel "full" and "empty"
- Heating: recommended for extreme temperatures or temperature fluctuations
- Protective roofs: protection against external influences
- Feed hopper for cable feed and strain relief
- Limit switch: for limiting the end position
- Cable clamps: for safe cable routing
- Support rollers: for cable routing



Construction of a spiral-wound cable reel:

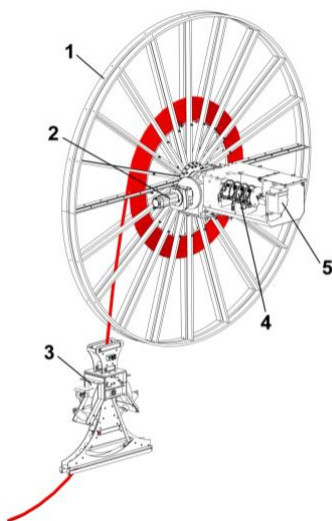

- 1 - Reel body
- 2 - Drive motor
- 3 - Roller deflection with monitoring device
- 4 - Slip ring assembly
- 5 - Fibre optic cable / rotary transformer



Elektrotechnische Geräte Böhlitz-Ehrenberg GmbH

EGB, from the idea to the realisation - everything from a single source

Whether project planning and original equipment, modernisation, maintenance or repair, as a system supplier EGB offers its customers a comprehensive all-round service with expert advice.

With almost 100 years of experience in development and production as well as installation and commissioning, we are the right partner to realise your projects. Our spiral-wound cable reels are just a small selection from our extensive portfolio of cable reels with slip ring assemblies and hose reels, from small and handy to gigantic with cable pull-off lengths of up to 3,000 metres.



Visit us at: www.egb-be.de

or meet us in person:

Ludwig-Hupfeld-Straße 6
04178 Leipzig, Germany

 +49 341 44 81 0



