

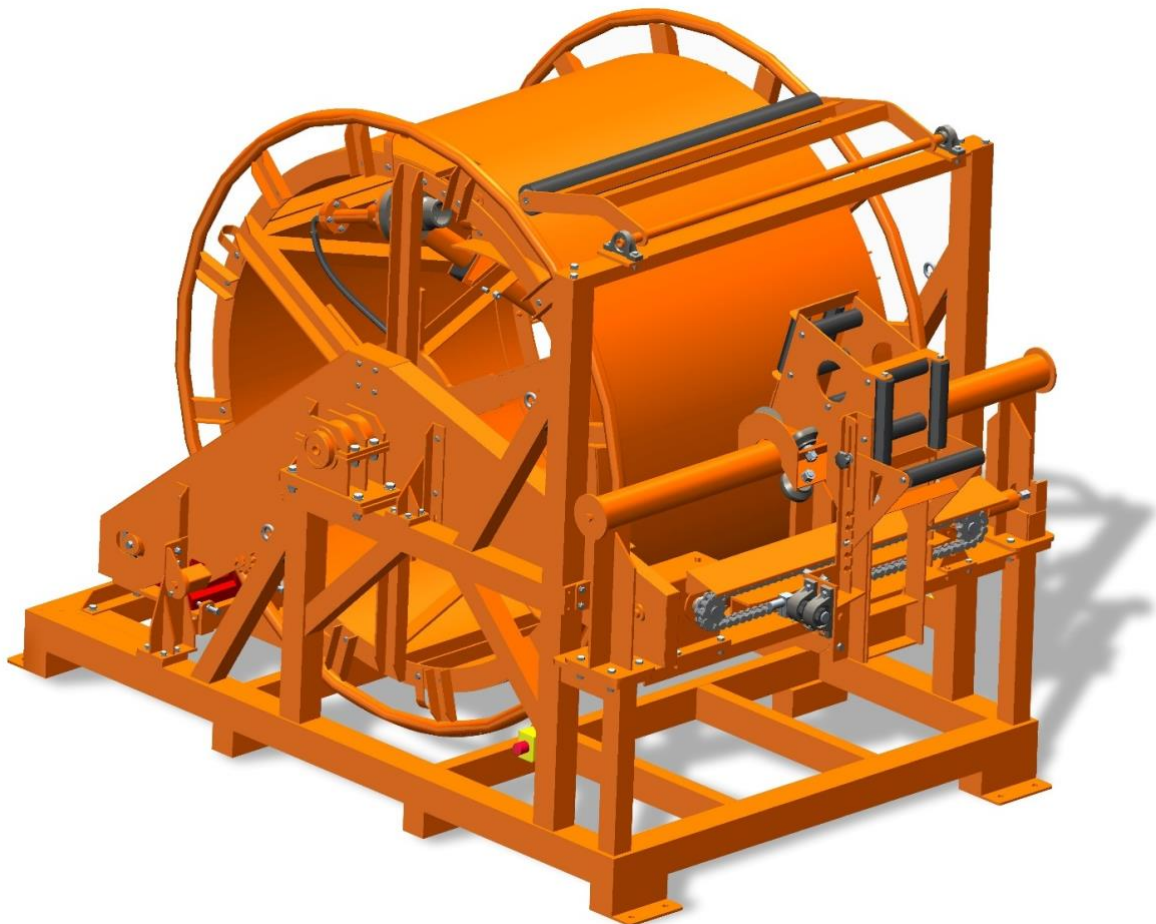

Elektrotechnische Geräte Böhlitz-Ehrenberg GmbH

Your specialist for hose reels and special accessories



We offer:

- Project planning, new construction, and conversion according to your specifications or joint technical design on request
- Regular maintenance service
- Modernisation of your systems and repairs
- Immediate assistance in the event of a fault, even with units from other manufacturers
- Spare parts service



Hose reels from EGB from standard solutions to high-tech customised products

Hose reels with motor or spring drive are used to convey a variety of media such as water, gases, chemicals, paints and oils or greases through hoses to moving or mobile consumers. Thanks to their robust design and construction, they can be used in almost any industrial environment and work reliably under extreme conditions and with enormous temperature fluctuations.



Our quality promise:

Our hose reels are characterised by top quality thanks to the highest standards in material selection and the manufacturing process. Whether for 24/7 use in mechanical engineering or in environmental technology, in power plants or in open-cast mining, our highly functional hose reels for horizontal, vertical or flexible applications withstand all challenges and conditions, and this with an extremely long service life of the devices.

Almost 100 years of technical experience, engineering expertise and quality "Made in Germany".

Each of our hose reels consists of the following three basic components:

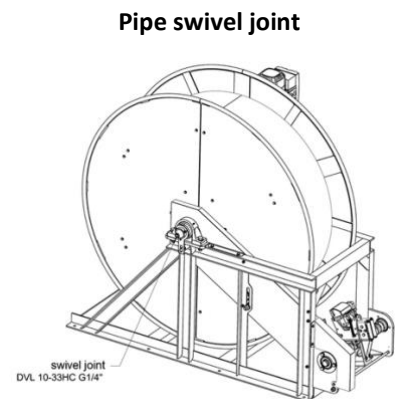
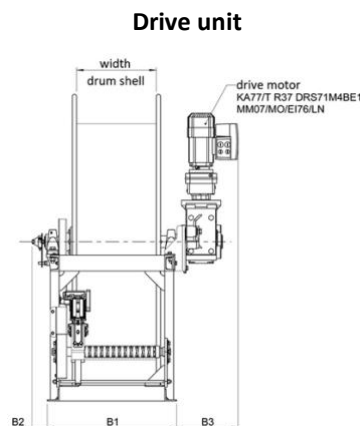
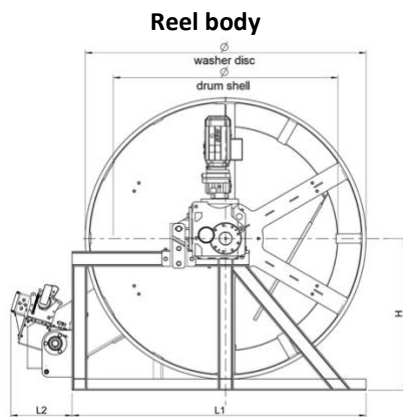

Hose reels are used with spiral (mono- or duo-spiral) or cylindrical (wild or guided) reels. Depending on the specific design or the length of the hoses, winding is carried out using an integrated spooling device. Our devices are manufactured in painted or powder-coated steel, stainless steel, aluminium or impact-resistant plastic and can therefore be used for a wide range of applications, e.g. also in medical technology and in the food industry.

Hose reels can be driven electrically, hydraulically, pneumatically or by spring force. The choice of drive type depends on the respective area of application, required hose lengths and any safety standards to be observed for the respective hose reel.

Swivel joints are used to transport and transfer liquid or gaseous media from a swivelling or endlessly rotating machine part to a fixed, stationary machine part. This is done using one-way or multi-way transmitters, depending on the media to be transported and the specific pressure conditions.



Product features of our hose reels

- Operating pressures up to 300 bar
- Winding lengths up to 1,000 m, double hose systems for customised products
- Delivery with or without hose, nominal hose diameters from DN 10 to DN 200
- Storage on one or both sides
- Excellent protection against corrosion and environmental influences
- Available with or without spring return and with fixed or variable backstop
- Hoses installed by us can be selected for media with temperatures from 0°C to 80°C
- Hose qualities available for every application, rigid or flexible, rubber spiral hoses or fabric hoses, including certified hoses for the food or medical sector, with non-abrasive inner or outer material

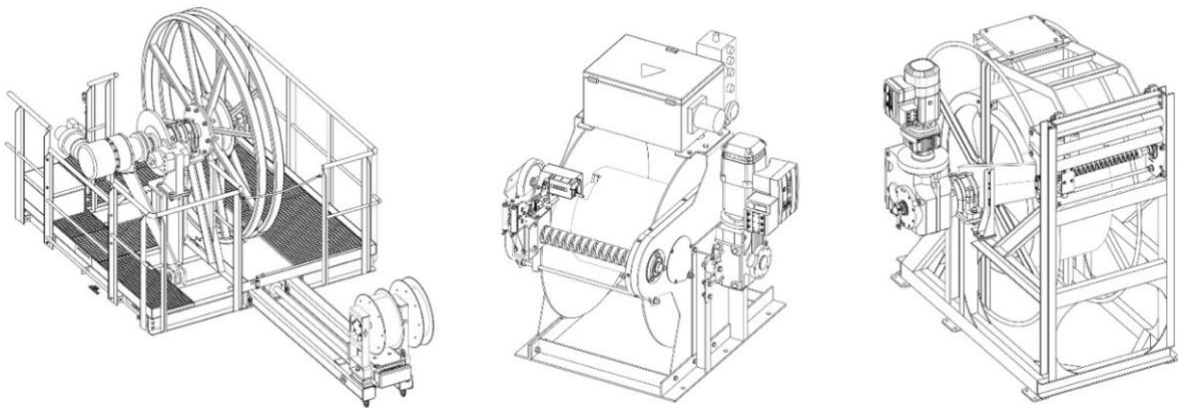

Accessories

- Spooling devices: spindle- or chain-driven, these ensure that the hose is wound or unwound in an orderly fashion of the hose on the reel body
- Roller deflector: deflection of the hose guide
- Support stand: mounting of the roller deflector above well inlets
- Support rollers: Support of the hose over a distance
- Geared cam limit switch: Monitoring of the operating states, reel "full" and "empty"
- Safety and brake units: to prevent personal injury or damage to property
- Rigid or swivelling wall, ceiling and floor mountings: for locking reels in place
- Chassis for reel unit and hose trolleys: for even more flexible and mobile use
- Length counters: for recording the unwound hose lengths

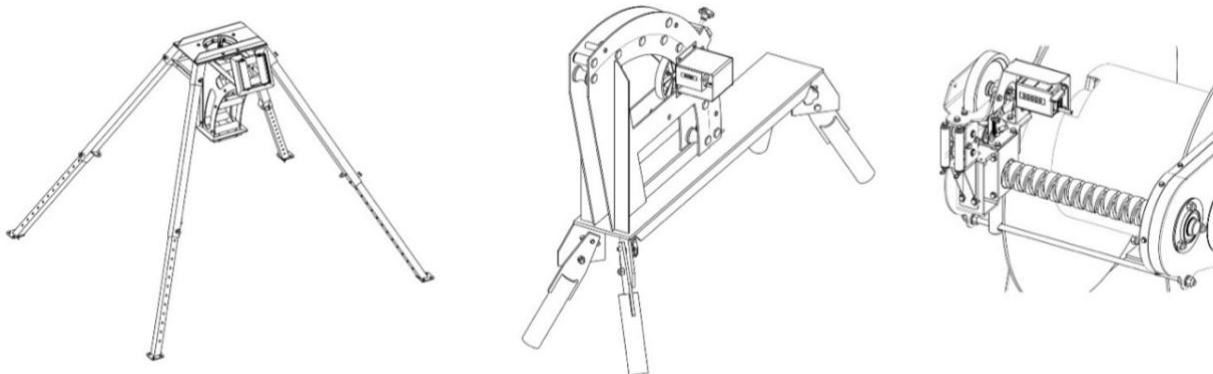



EGB, from the idea to the realisation - everything from a single source

Whether project planning and original equipment, modernisation, maintenance or repair, as a system supplier EGB offers its customers a comprehensive all-round service with expert advice.

With almost 100 years of experience in development, production, installation and commissioning, we are the right partner to realise your projects. Our hose reels for industrial use are just a small selection from our extensive portfolio of hose and cable reels, from small and handy to gigantic with up to 3,000 m realisable cable pull-off lengths.

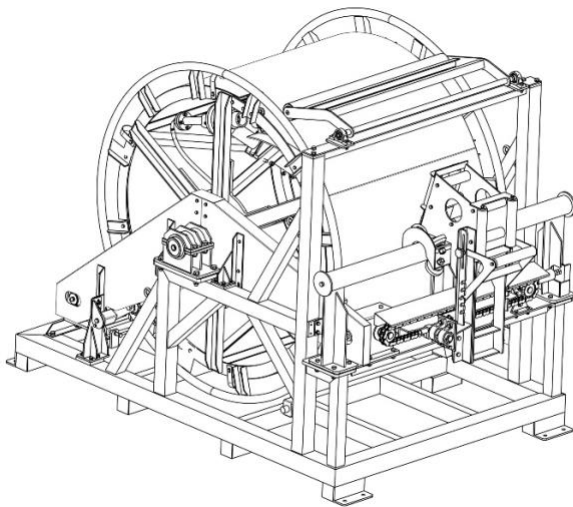

Visit us:



www.egb-be.de



info@egb-be.de



+49 341 44 81 0



Ludwig-Hupfeld-Straße 6, 04178 Leipzig, Germany



